

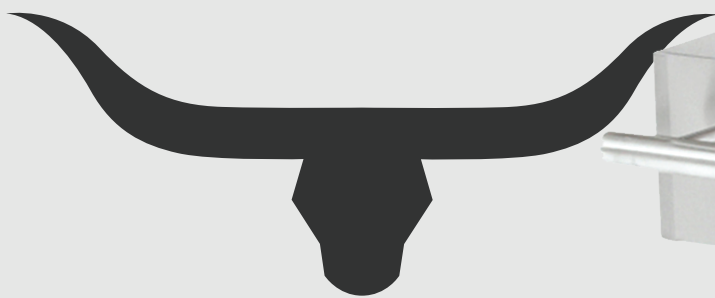

READ THE FLAMING MANUAL!

[911963] LONGHORN BUILT-IN BBQ 30"

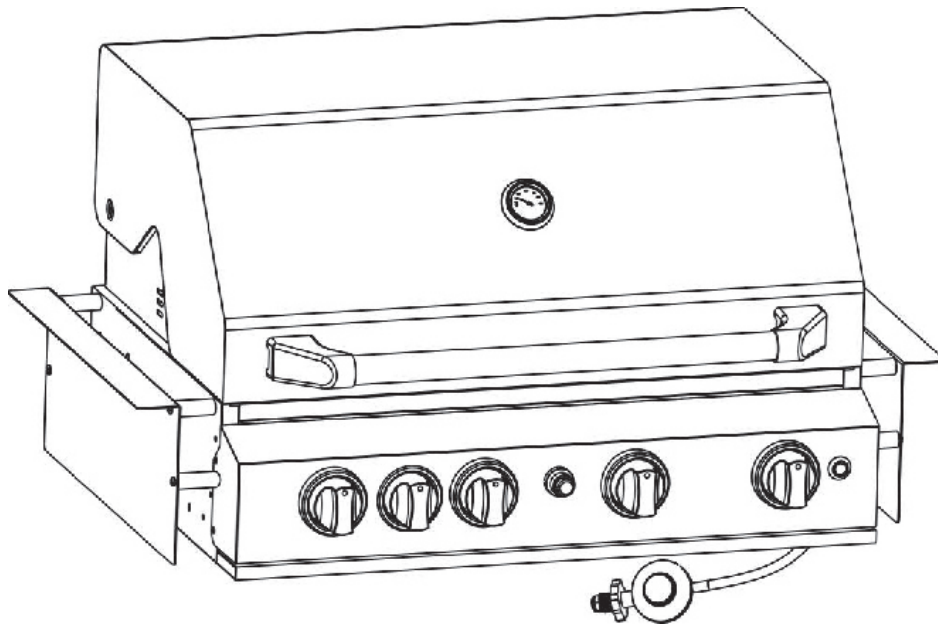



⚠ WARNING

To reduce the risk of fire, burn hazard or other injury, read the instruction carefully and be sure your appliance is properly installed and assembled.

⚠ WARNING
FOR OUTDOOR USE ONLY

⚠ DANGER

If you smell gas:

1. Shut off gas to the appliance;
2. Extinguish any open flame;
3. Open lid;
4. If odor continues, keep away from the appliance and immediately call your gas supplier or your fire department.

⚠ WARNING

The grill head is heavy and will require two or more people to lift and position onto the grill cart when assembly

⚠ WARNING

Do not try lighting this appliance without first reading the "LIGHTING INSTRUCTION" section of this manual

⚠ WARNING

TO INSTALLER:

Test operation of the appliance and instruct the user before leaving. Ensure the appliance is commissioned correctly before handing over to the user.

⚠ WARNING

Conversion to natural gas only done by authorized persons

⚠ WARNING

Always keep the electrical components in dry situation.

OUTDOOR USE ONLY

This appliance shall only be used in above ground open-air situations with natural ventilation, without stagnant areas, where gas leakage and products of combustion are rapidly dispersed by wind and natural convection.

Any outdoor enclosure in which the appliance is used shall comply with one of the following:

- An enclosure with walls on all sides, but at least one permanent opening at ground level and no overhead cover. See Figure 1.
- Within a partial enclosure that includes an overhead cover and no more than two walls. See Figure 2 & 3.
- Within a partial enclosure that includes an overhead cover and more than two walls, the following shall apply:
 - *At least 25% of the total wall area is completely open; and
 - *At least 30% of the remaining wall area is open and unrestricted. See Figure 4 & 5.
- In the case of balconies, at least 20% of the total of the side, back and front wall areas shall be and remain open and unrestricted.

The following diagrams provide a diagrammatic representation of outdoor areas. Rectangular areas have been used in these figures - the same principles apply to any other shaped area.

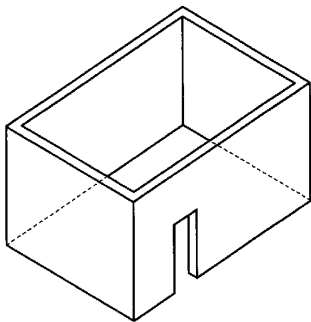

Figure 1 - Enclosure with walls on all sides but

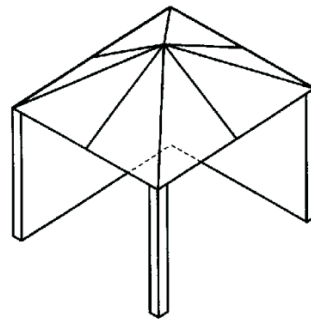
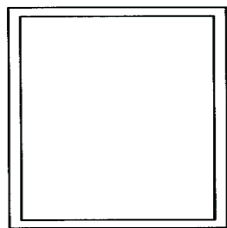

Figure 2 - Partial Enclosure with overhead cover and no more than 2 walls

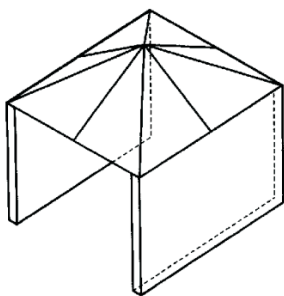
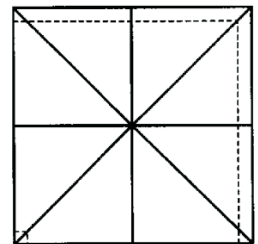

Figure 3 - Partial Enclosure with overhead cover and no more than 2 walls

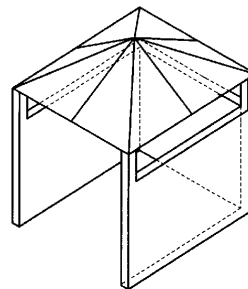
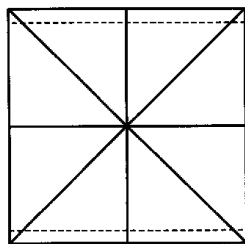

Figure 4 - Open side at least 25% of total wall area
30% or more in total of the remaining wall area is
open and unrestricted.

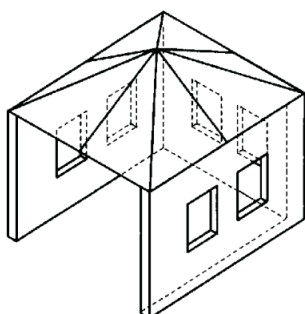
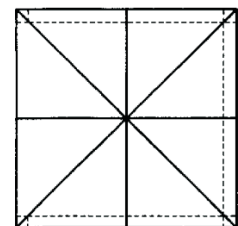
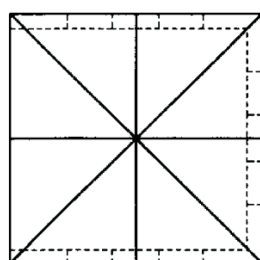

Figure 5 - Open side at least 25% of total wall area.
30 percent or more in total of the remaining wall area
is open and unrestricted



PLEASE DO

- Use spanner to tighten all gas fittings
- Check all gas hose and line connection for damage, cuts or cracks each time for using the appliance.
- Always leak test with soapy water
- Check all burners regularly for insect nets such as spiders, ants, etc. Nets are dangerous and need to be fully cleaned.
- Have the gas cylinder filled by an authorized gas supplier
- Always wear protective gloves when handling hot component
- Clean and maintain the appliance after each using.
- USE grill at least 1.5 m from any wall or surface, combustible material, gasoline, flame liquids or vapors
- "Burning off" the barbecue after every use (for approx 15 minutes) will keep excessive food residue to a minimum.

PLEASE DO NOT

- Lean over appliance when lighting
- Store combustible material, gasoline or flammable liquids or vapors within vicinity of appliance
- Use appliance with any cover on
- Use plastic or glass utensils on the appliance.
- Use the appliance in strong winds
- Dismantle control valves
- Test for gas leaks with a naked flame
- Store spare gas cylinders in the cabinet
- Lay the gas cylinder down (always keep upright)
- Use appliance indoors
- Modify the constructions of the appliance or the size of any burner, injector orifice or any other components
- Move the appliance during using
- Obstruct any ventilation of the appliance
- Allow the flexible gas supply hose or any electrical cord to come in contact with any heated surface of the appliance
- Use charcoal or any other solid fuel in this appliance
- Disconnect any gas fittings while the appliance is in using
- Use a rusty or dented gas cylinder with a damaged gas valve
- Fill the gas cylinder beyond 80% cap

GAS CYLINDER INFORMATION



WARNING

- This appliance is designed to be used with a gas cylinder not exceeding (Australia 9KG);
- The gas cylinder supply valve must be turned off when the appliance is not in use.
- Gas cylinders must be stored outdoors, out of reach of children and must not be stored in a building, garage or any other enclosed area.
- The gas cylinder used must incorporate a safety collar to protect the valve assembly.
- Never store a spare cylinder under the barbecue shelves or inside the trolley housing.
- Any LPG cylinder not attached to the appliance for use should be stored outdoors and well away from this appliance.

When disconnecting and removing the gas cylinder for the purpose of refilling, always observe the following procedure.

- Ensure that all gas control valves on the appliance and the gas cylinder are turned off before disconnecting the regulator from the cylinder.
- Do not smoke or use a naked flame near the appliance or gas cylinder while disconnecting the gas line between the appliance and gas cylinder.
- Remove the gas cylinder from the enclosure before disconnecting the regulator from the appliance
- Tighten all connections before placing the gas cylinder back in its enclosure.
- The gas leak testing procedure should be conducted every time the gas cylinder is refilled and reconnected to the appliance before using the appliance.

Regulator

1. Check that all control knobs are in the 'Off' position.
2. Make sure the cylinder valve is off.
3. Remove the protective cap from the cylinder if present.
4. Leak test the connection with a soapy water solution.

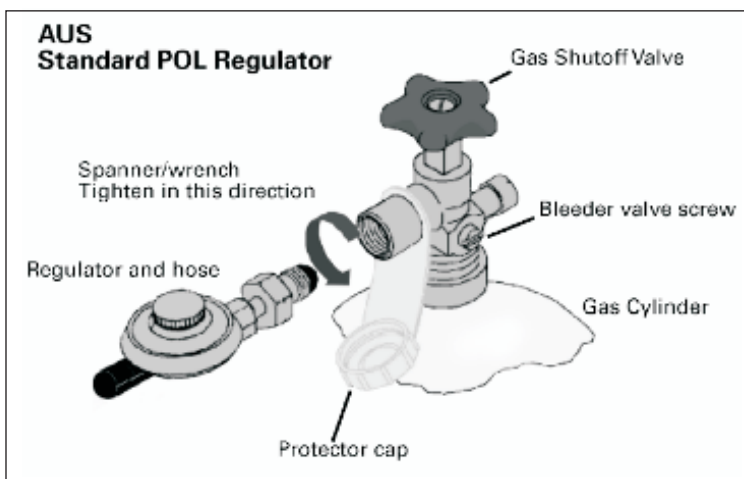

GAS LEAK TEST



WARNING

Never use a naked flame to check for gas leaks.

Always use the following procedure to check for gas leaks.

1. In a small container, mix up a solution of water and detergent or soap.
2. Make sure that the gas supply valve on the gas cylinder is turned on.
3. Make sure that the gas control valves on the appliance are all turned off.
4. Using a brush or spray bottle apply the solution to the gas line and each joint in the gas line.
5. Bubbling of the solution will indicate that there is a leak present.
6. Re-tighten or re-seal any joints that are leaking.
7. If a leak persists then contact your distributor or the manufacturer for assistance..

SAFETY PRACTICE TO AVOID INJURY

- Inspect the gas supply hose prior to turning on the gas. If there is evidence of cuts, wear, or abrasion, it must be replaced prior to use.
- Only the pressure regulator and hose assembly supplied with the appliance should be used. Never substitute regulator for those supplied with the appliance. Contact customer service for proper replacement.
- Leak check the hose and regulator connections with a soap and water solution before operating the appliance.
- DO NOT turn the gas at the LP gas cylinder unless the gas hose is properly connected to the side burner gas pipe system and all burners are in the "OFF" position.
- Keep a spray bottle of soapy water near the appliance and check the connection before each use.

When properly cared for, your appliance will provide safe, reliable service for many years. However, extreme care must be used as the appliance intense heat that can increase accident potential.

When using this appliance basic safety practices must be followed, including following:

- Do not repair or replace any part of the grill unless specifically recommended in this manual. All other service should be referred to a qualified technician.
- The appliance is for outdoor use only.
- The appliance is not intended to be installed in or on recreational vehicles and /or boats.
- Children should not be left alone or unattended in an area where the appliance is being used. DO NOT allow children to sit, stand or play on or around the appliance at any time.
- Do not store items of interest to children around or below the grill or cart. Do not allow children to crawl inside the cart.
- Never let clothing, pot holders or other flammable materials come in contact with or too close to any grate, burner or hot surface until it has cooled. The fabric could ignite, causing serious personal injury.

- For personal safety, wear proper apparel. Loose fitting garments or sleeves should never be worn while using this appliance. Some synthetic fabrics are highly flammable and should be not worn while cooking.
- Only certain types of glass, ceramic earthenware , or other glazed utensils are suitable for grill use. Other types of material may shatter with sudden temperature changes. Use only low or medium heat settings in accordance with the manufacture's guidelines.
- Do not heat unopened food containers as a built-up of pressure may cause the containers to burst.
- Use a covered band when opening the grid lid.
- Never lean over an open grill.

When lighting a burner, always pay close attention to what you are doing. Make certain you are aware of which burner you are lighting so that your body and clothing remain clear of open flames.



WARNING

When using the grill

- DO NOT touch the grill rack, burner grate or immediate surroundings as these areas become extremely hot and could cause burns. Use only dry potholders. Moist or damp potholders on hot surfaces may cause steam burns.
- DO NOT use towel or bulky cloth in place of potholders.
- Grease is flammable, let hot grease cool before attempting to handle it. DO NOT allow grease deposit to collect in the grease tray. CLEAN THE GREASE TRAY OFTEN.
- DO NOT use aluminum foil to line the grills rack or grill bottom.

For proper lighting and performance of the burners, keep the burner pot clean. it is necessary to clean them periodically for optimum performance. The burners will only operate in one position and must be mounted correctly for safe operation. Exercise caution when cleaning the grill. To avoid steam burns, DO NOT use a wet sponge or cloth to clean the grill while it is hot. Some cleaners produce noxious fumes or can ignite if applied to a hot surface.

NEVER USE A DENTED OR RUSTY PROPANE GAS CYLINDER.

DO NOT use the grill to cook excessively fatty meats or other products which promote flare-ups. DO NOT operate the grill under unprotected combustible constructions. USE only well ventilated areas. Do not use in buildings, garages, sheds or other such enclosed areas.

This grill is designed for optimum performance without the use of briquettes.

DO NOT place briquettes on the flame tamers as this will block the vent to the grill burners. Adding briquettes can damage ignition components.

Never use the grill in extremely windy conditions. If located in a consistently windy area, a windbreak will be required.

ELECTRICAL COMPONENTS



WARNING

Electrical Groundings Instructions for Transformer- This appliance (Transformer) is equipped with a plug and should be plugged directly into a properly grounded receptacle. When installed, must be electrically grounded in accordance with local codes.

DO NOT cut or remove the grounding prong from this plug.

- 1.To protect against electrical shock, DO NOT immerse cord or plugs in water or other liquids.
- 2.Uplug from the outlet when not in use and before cleaning. Allow to cool before putting on or taking off parts.
- 3.DO NOT operate any outdoor cooking gas appliance with a damaged cord, plug, or after the appliance malfunctions or has been damaged in any manner.
4. DO NOT let the cord hang over the edge of a table or touch hot surface.
5. DO NOT use an outdoor cooking gas appliance for purpose other than intended.
6. When connecting, first connect plug to the outdoor cooking gas appliance then plug appliance into the outlet.
7. Use only a Ground Fault Interrupt(GFI) protected circuit with this appliance.

LIGHTING INSTRUCTIONS

This barbecue is designed for use outdoors, away from any flammable materials.

It is important that there are no overhead obstructions and that there is a minimum distance of 1000mm from the side or rear of the appliance.

It is important that the ventilation openings of the cylinder compartment are not obstructed. No modifications should be made to any part of this barbecue and repairs and maintenance should only be carried out by an authorized person.

DO NOT let children operate or play near grill.

DO NOT use charcoal or ceramic briquettes in a gas grill

DO NOT light or use the side burner with the lid in the closed position.

DO NOT attempt to light burner with lid closed. A buildup of non-ignited gas inside a closed grill is hazardous.



WARNING

The side burner is designed for pot/Pan with diameter 60-260mm

Side burner lid can not be used as a work table. DO NOT put anything on the side burner lid while it is not working

To light the grill

1. Open the lid and make sure all the knobs are on the OFF position.
2. Push down the knob and turn the knob anticlockwise to HIGH position, then keep pressing the igniter for 2-3 seconds (a sound could be heard), thus the burner could be lit. If the burner does not light, turn off the knob and wait for 5 minutes then repeat this process.
3. Adjust the heat by turning the knob to the High / Low position.
4. To light the other burners, repeat the same process for the adjacent burner and continue in sequence until all the burners are lit.
5. To turn the barbecue OFF, turn the cylinder valve or regulator switch to the "OFF" position and then turn all of the control knobs on the barbecue clockwise to the "OFF" position.

For Match- Lighting:

1. For Main burner, place the match into match holder chain and fire the match, then put the match into the lighting hole on the right side of the fire box;
2. For side burner, place the fired match on the holes of the side burner head.
3. Push down and turn the knob anticlockwise to HIGH position, then the burner can be lit. If the burner does not light, turn off the gas tap and wait for 5 minutes then repeat. .

Before cooking for the first time, light on all the main burners and keep burning for 15 minutes with the lid closed and knob at HIGH position. This will "heat clean" the internal parts and dissipate odor from the painted finish. The color of cooking area may get little change. It is normal and it is the nature of material.



WARNING

While igniting main burner and infrared rear burner, make sure the lid is in open situation. DO NOT IGNITE WITH SIDE BURNER LID CLOSED. DO NOT CLOSE SIDE BURNER LID WHEN SIDE BURNER IS IN OPERATION.

While cooking with the hood closed and with all the burners on, makes sure all these burners are in the LOW flame position.

CARE AND MAINTENANCE

Stainless Steel

There are many stainless steel cleaners available. Always use the mildest cleaning process first, scrubbing in the direction of the grain. DO NOT use steel wool as it will scratch the surface. To touch up noticeable scratches in the stainless steel, and very lightly with dry 100 grit sand paper in the direction of the grain.

Grease specks can gather and bake onto the surface of the stainless steel, giving the appearance of rust. For removal, use an abrasive pad with s stainless steel cleaner.

Cooking Grates

The easiest way to clean the grill is immediately after cooking is completed and the flames have been turned off.

Wear a barbecue mitt to protect your hand from heat and steam.

Scrub the hot cooking grates by dipping a bristled barbecue brush in tap water. Cleaning will be more difficult if the grill is allowed to cool.

Grease Pan

The grease pan should be emptied, wiped down and washed after each use with a mild detergent and warm water solution. Check the grease pan frequently and do not allow excess grease to accumulate and flow out of the grease pan.

Grill Burner

Extreme care should be taken when removing a burner. It must be correctly centered on the orifice before any attempt is made to relight the grill. Frequency of cleaning will depend on how often you use the grill.

Failure to properly place the burner over the orifice could cause a fire to occur behind and beneath the valve panel, thereby damaging the grill and making it unsafe to operate.

Before cleaning, make sure the gas supply and control knobs are in the 'OFF' position and the burners have cooled.

Follow these instructions to clean parts of burner assembly or if you have trouble igniting grill.

1. Turn gas off at control knobs and LPG Tank.
2. Remove cooking grates, grease tray and grease cup.
3. Remove screw at end of burner using a screwdriver.
4. Carefully lift each burner up and away from valve openings.
5. Wire brush entire outer surface of burner to remove food residue and dirt.
6. Clean any blocked ports with a stiff wire such as an open paper clip.
7. Check burner for damage, due to normal wear and corrosion some.

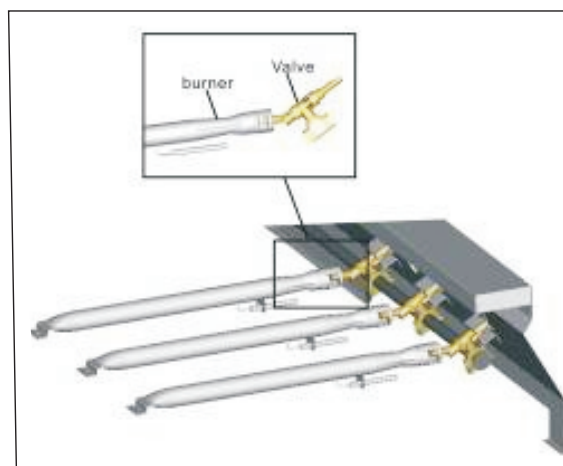

We suggest following ways to clean the burner tubes

- Bend a stiff wire (a light weight coat hanger works well) into a small hook. Run the hook through each burner tube and burner several times
- Use a narrow bottle brush with a flexible handle (DO NOT use a brass wire brush), run the brush through each burner tube and burner several times.
- Wear eye protection: use an air hose to force air into the burner tube and out the air ports. Check each port to make sure air comes out each hole

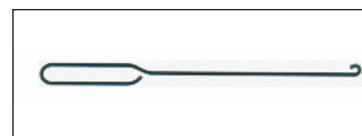

WARNING

NATURAL HAZARD SPIDERS

FACT: sometimes spiders and other insects climb into the grill tubes to the burners. The spiders spin webs build nests and lay eggs. The webs or nests can be very small, but they are very strong and can block the flow of gas.

Clean burners prior to use after storing, at the beginning of grilling season or after a period of one month not being used.

Spider guards are on the air intakes in an effort to reduce this problem, but it will not eliminate it! An obstruction can result in a "flashback" (a fire in the burner tubes). The grill may still light, but the obstruction does not allow full gas flow to the burners.



ABNORMAL OPERATION



WARNING

Any of the following are considered to be abnormal operation and may require service

- Yellow tipping of the yellow flame
- Sooting up of grills plates
- Burners not igniting properly
- Burners failing to remain alight
- Burner extinguished by trolley doors
- Gas valves, which are difficult to turn

TECHNICAL DATA

AGA Approval No: AGA 8138 G

Model No.: 401WB / 911963

Gas Type: Universal LP Gas & Natural Gas

Test Point Pressure: Universal LP Gas- 2.75 kpa
Natural Gas-1.0KPA

Total Nominal Gas

Consumption: Universal LP Gas-65MJ/h
Natural Gas-55 MJ/h

Nominal Gas Consumption & Injector size:

*** Universal LP Gas**

- Main Burners: 13MJ/h x 4 Injector size 0.98mm
- Back Burner: 13MJ/h Injector size 0.98mm

*** Natural Gas**

- Main Burners: 11MJ/h x 4 Injector size 1.50mm
- Back Burner: 11MJ/h Injector size 1.65mm



CAUTION

For Use outdoors only

Conversion of natural gas only to be done by authorized person

The maximum cylinder size for use with this appliance is 9kgs

The thread type of this appliance is G1/4B-19.

EXPANDED VIEW & PART LIST

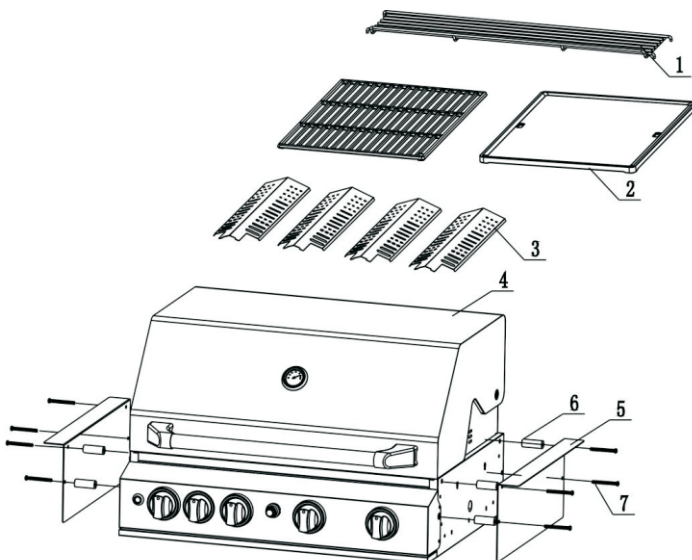

ASSEMBLY INSTRUCTIONS

Tools required:
1. Phillips Head Screwdriver
2. Gloves

1. Built-in bracket assembly

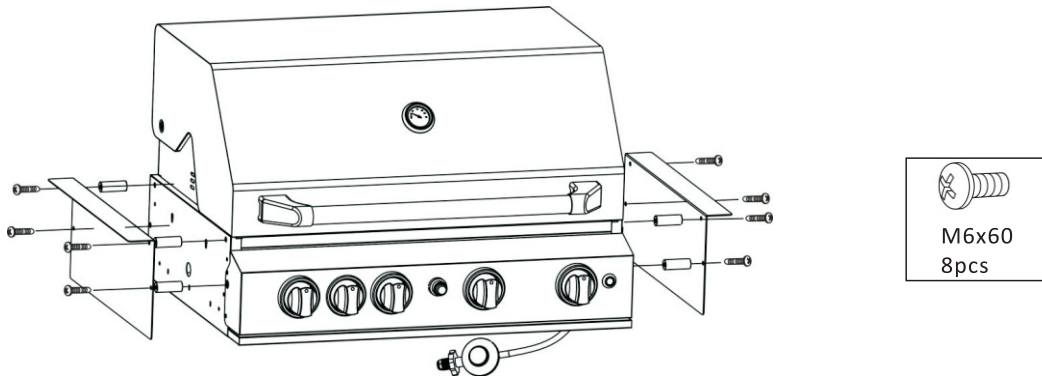

2. Flame diffuser assembly

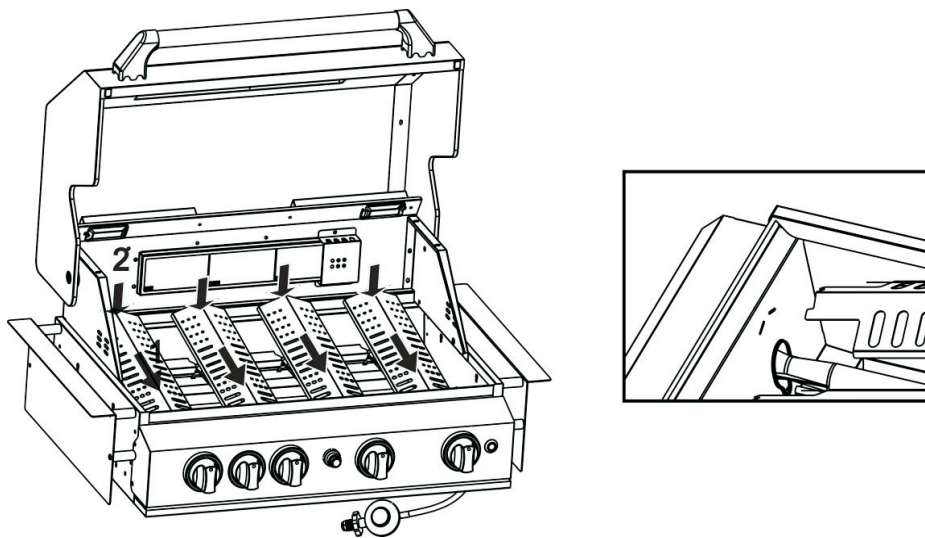

3. Cooking grid/cooking plate assembly

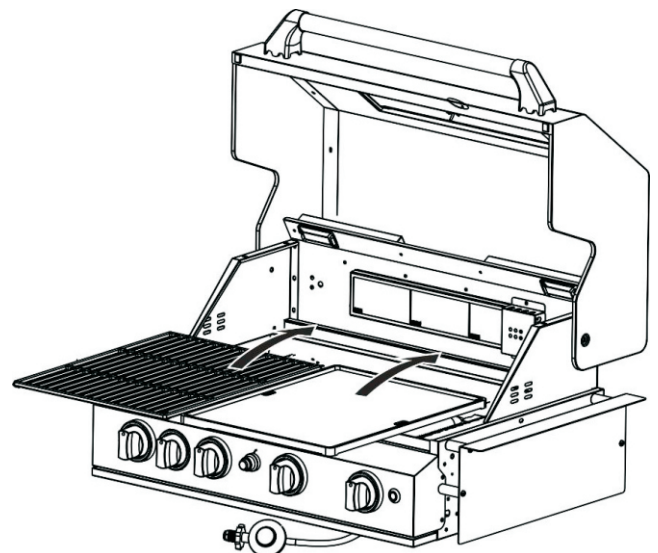

ASSEMBLY INSTRUCTIONS

4. Warming rack assembly

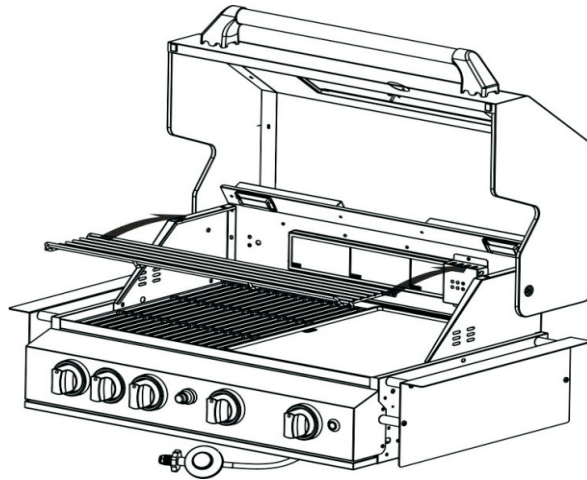

5. 1xAA battery (Battery is not included)

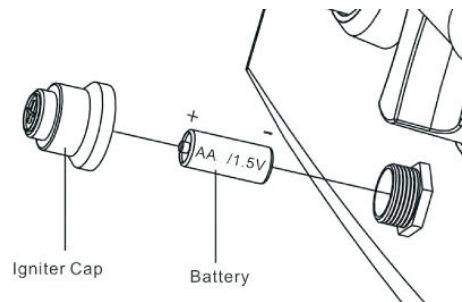

* For Rotisseries kit

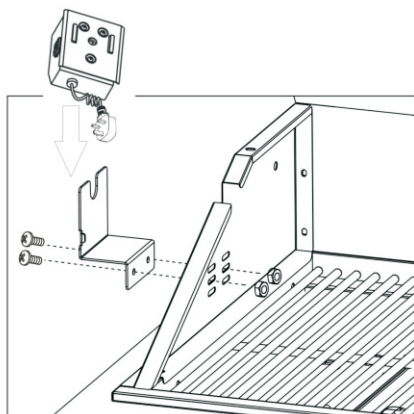

Note:
2 Motor brackets needed for using

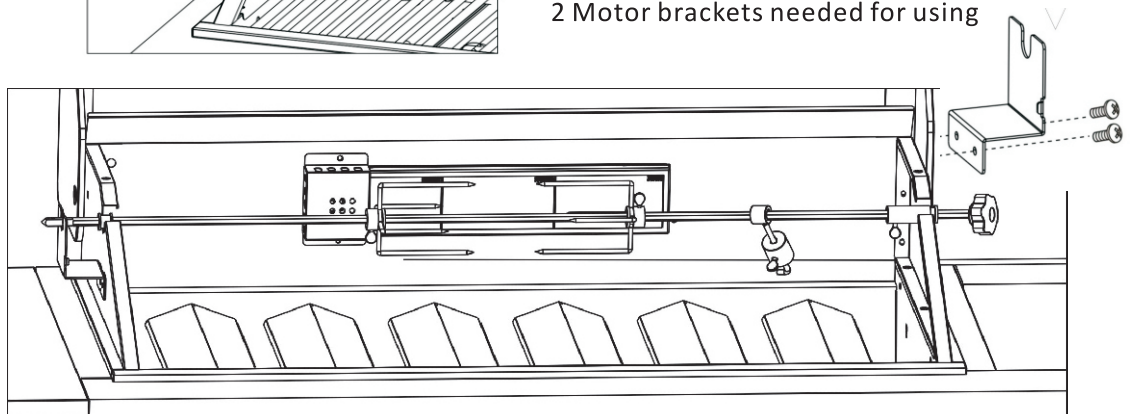

BUILT IN INSTALLATION



WARNING

1. Please follow following instruction to Install.
2. The minimum clearance of the sides of the BBQ to walls needs to be 50mm.
3. DO NOT block any ventilation of the BBQ.
4. The enclosure material for the cutout is not combustibles
5. Do Not place gas cylinder underneath the barbeque, keep required clearance.
6. Ensure Floor clearance are kept and cavity underneath the barbeque.

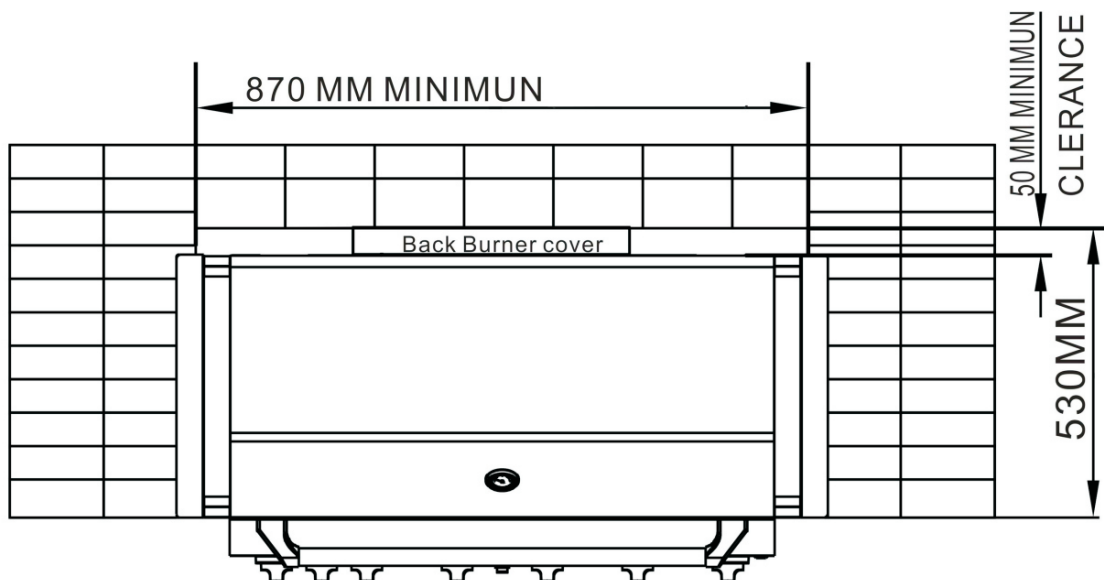
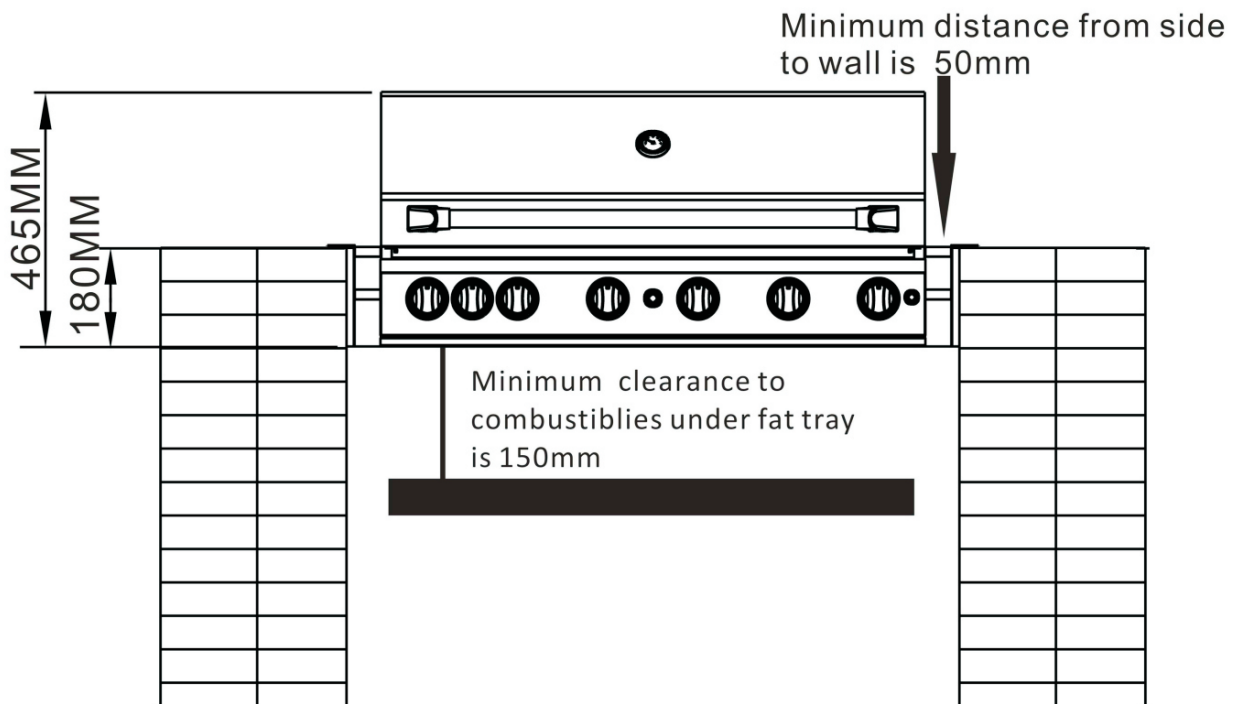

SERVICE AND CONTACT INFORMATION

Postal

Trade Tested Limited, PO Box 9117, Newmarket Auckland 1149, New Zealand

Telephone

0800 800 880

Email

support@tradetested.co.nz

Website

www.tradetested.co.nz

Our manuals are constantly being reviewed however if you should find an error, omission or if there is anything you find unclear please contact us for assistance.

